

BG-CP-A with BGI Sensors

Advanced Control Panel

WIRE GUIDE

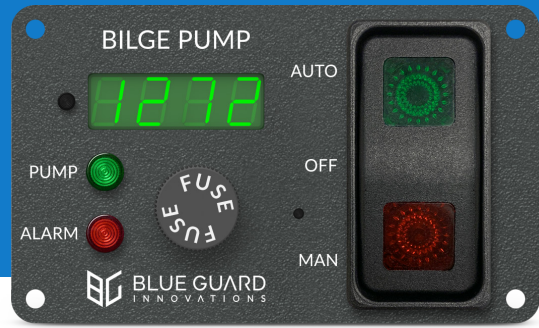

All wiring on the vessel shall be performed by a QUALIFIED MARINE ELECTRICIAN and in accordance with the "Fire Protection Standard for Motor Craft", NFPA No. 302, The Standards of the American Boat and Yacht Council, Inc., and the USCG Safety Standards for Boat Electrical Systems (33 CFR 183).

Supply Negative = GND

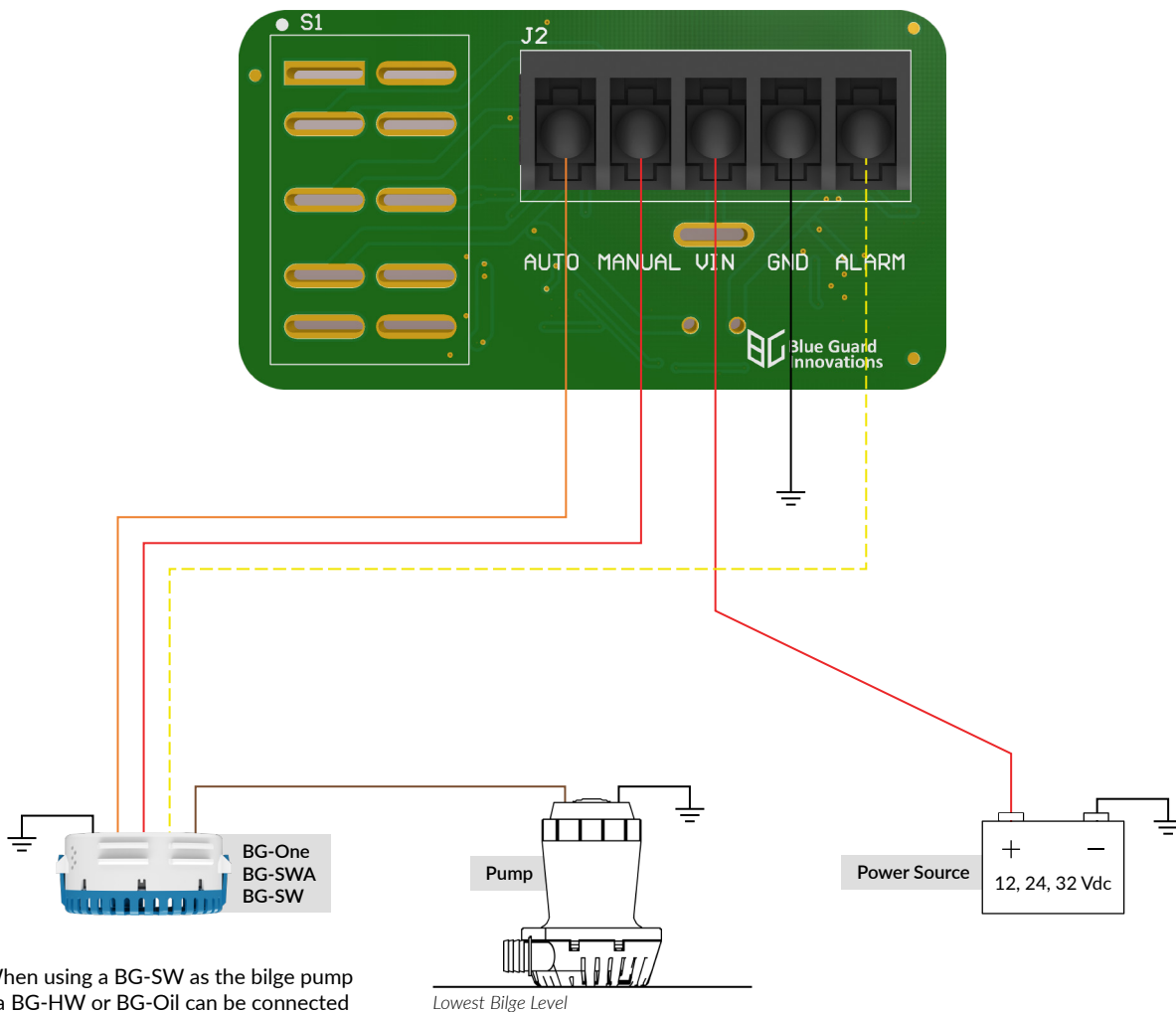

Note: When using a BG-SW as the bilge pump switch, a BG-HW or BG-Oil can be connected to the alarm input.