

BLUE GUARD INSTALLATION GUIDE

BG-ONE



Warranty Information

Blue Guard Innovations, LLC 520 Zang Street, Suite 221 Broomfield, Colorado 80021 warrants to the original consumer purchaser that this product will be free from defects in material and workmanship, providing that the unit is not opened or otherwise abused for a period of three (3) years from the date originally purchased unless otherwise noted or sold by the manufacturer. The exclusive remedy of the consumer purchaser in the event the product is defective is to return the product to Blue Guard Innovations, LLC at the above address, freight prepaid with original sales receipt. When items are returned and found to be working, or when the warranty has been voided, the cost of shipping back to the customer will be charged to the customer. Returned product is considered abandoned property following 30 days with no response to Blue Guard Innovations, LLC Customer Service. IMPORTANT: FOR THIS WARRANTY TO BE EFFECTIVE, the product MUST BE SUPPLIED WITH PROOF OF ORIGINAL PURCHASE DATE OF THE PRODUCT. THE ACCEPTANCE BY BLUE GUARD INNOVATIONS, LLC OF ANY PRODUCT RETURNED SHALL NOT BE DEEMED AN ADMISSION THAT SUCH PRODUCT IS DEFECTIVE OR IN VIOLATION OF ANY WARRANTY. THE COMPANY RESERVES THE RIGHT TO REPAIR OR REPLACE THE PRODUCT. NO REPRESENTATIVE OR OTHER PERSON IS AUTHORIZED TO ASSUME FOR BLUE GUARD INNOVATIONS, LLC ANY ADDITIONAL LIABILITY IN CONNECTION WITH THE SALE OF ITS PRODUCTS OR TO ALTER THIS WARRANTY IN ANY WAY. IN NO EVENT WILL BLUE GUARD INNOVATIONS, LLC BE LIABLE FOR MORE THAN THE SALES PRICE OF THE PRODUCT. UNDER NO CIRCUMSTANCES WILL BLUE GUARD INNOVATIONS, LLC BE LIABLE FOR ANY LOST PROFITS, INCIDENTAL OR CONSEQUENTIAL COSTS, EXPENSES, OR DAMAGES, THE LIMITATION ON LIABILITY FOR LOST PROFITS, INCIDENTAL OR CONSEQUENTIAL COST EXPENSES OR DAMAGES SHALL SURVIVE ANY FAILURE OF ESSENTIAL PURPOSE OF THIS LIMITED WARRANTY. All wiring on the vessel shall be performed by a QUALIFIED MARINE ELECTRICIAN and in accordance with the "Fire Protection Standard for Motor Craft", NFPA No. 302. The Standards of the American Boat and Yacht Council, Inc., and the USCG Safety Standards for Boat Electrical Systems (33 CFR 183). Some states do not allow the exclusive or limitation of incidental or consequential damages, so the above limitation may not apply to you. NO EXPRESS OR LIMITED WARRANTY, INCLUDING WARRANTY OF MERCHANTABILITY AND FITNESS SHALL EXTEND FOR ANY PERIOD OF TIME GREATER THAN THREE (3) YEARS FROM THE DATE OF ORIGINAL PURCHASE OF THIS PRODUCT. Some states do not allow limitation on how long an implied warranty lasts, so the above limitation may not apply to you. CAUTION - Warranty void if seal on product is broken or product is tampered with in any way, if any electrical wire is cut back more than 4 inches, if electrical splices become submerged, or if product is installed contrary to instructions or warnings. Blue Guard Innovations, LLC 520 Zang Street, Suite 221 Broomfield, Colorado 80021.

Blue Guard systems are compatible with 12, 24, or 32 Vdc power.

To download product user manuals, go to: www.bluebgi.com/manuals

General Instructions

- Be sure to read, understand and follow the included instructions. Not following the below instructions may void your warranty.
- **WARNING:** Disconnect power from system before installation.
- Don't cut more than 4" of wire.
- To keep connections dry use waterproof adhesive-lined heat shrink terminals.
- Keep connections high and away from water or condensing moisture.
- Use a second layer of waterproof adhesive-lined heat shrink to completely encapsulate the connections.
- The negative wire must be connected to a bonded common ground point, i.e. with the ground point connected to the battery negative, and situated as close as possible to the battery negative terminal.
- Install properly rated fuse.
- Ensure that any additional wiring is the appropriate gauge for the distance and load (Refer to ABYC Standards).
- Seal any unused wires with waterproof adhesive-lined heat shrink to be protected from water or moisture.
- After installation is complete use the Config App to verify installation and test for proper functionality.

Mounting the BG-One

- BG-One must be mounted horizontally.
- BG-One snaps in and out of bracket (shown below).
- BG-One will activate approx. 1/4" up the strainer. Be sure to mount it high enough to allow the pump to prime.
- Mount with included mounting bracket or use pump mounting bracket MTB-250375 or MTB-312412 (sold separately).
- The BG-One will activate when liquid reaches 0.25" above the strainer (shown by dotted line below).
- The BG-One alarm will activate when oil is detected. When water is detected the pump will activate. When the BG-One detects air the pump will run for three seconds (factory default).

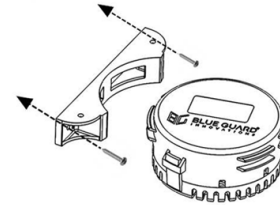

Mounting Bracket

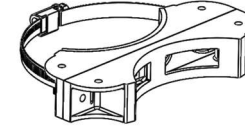

Pump Mounting Bracket
MTB-250375 or MTB-312412
(Sold Separately)

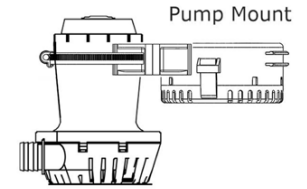

BG-One mounted to pump

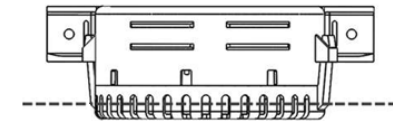

BG-One horizontal activation point

Installation: BG-One to BG-CP-A

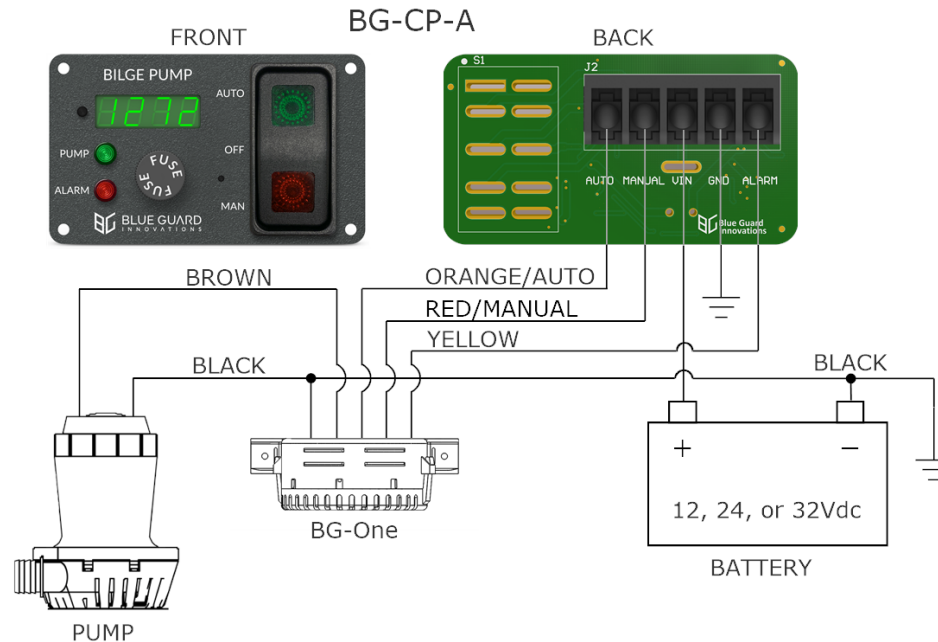

All wiring on the vessel shall be performed by a QUALIFIED MARINE ELECTRICIAN and in accordance with the "Fire Protection Standard for Motor Craft", NFPA No. 302. The Standards of the American Boat and Yacht Council, Inc., and the USCG Safety Standards for Boat Electrical Systems (33 CFR 183).

Installation: BG-One to Third Party Panel

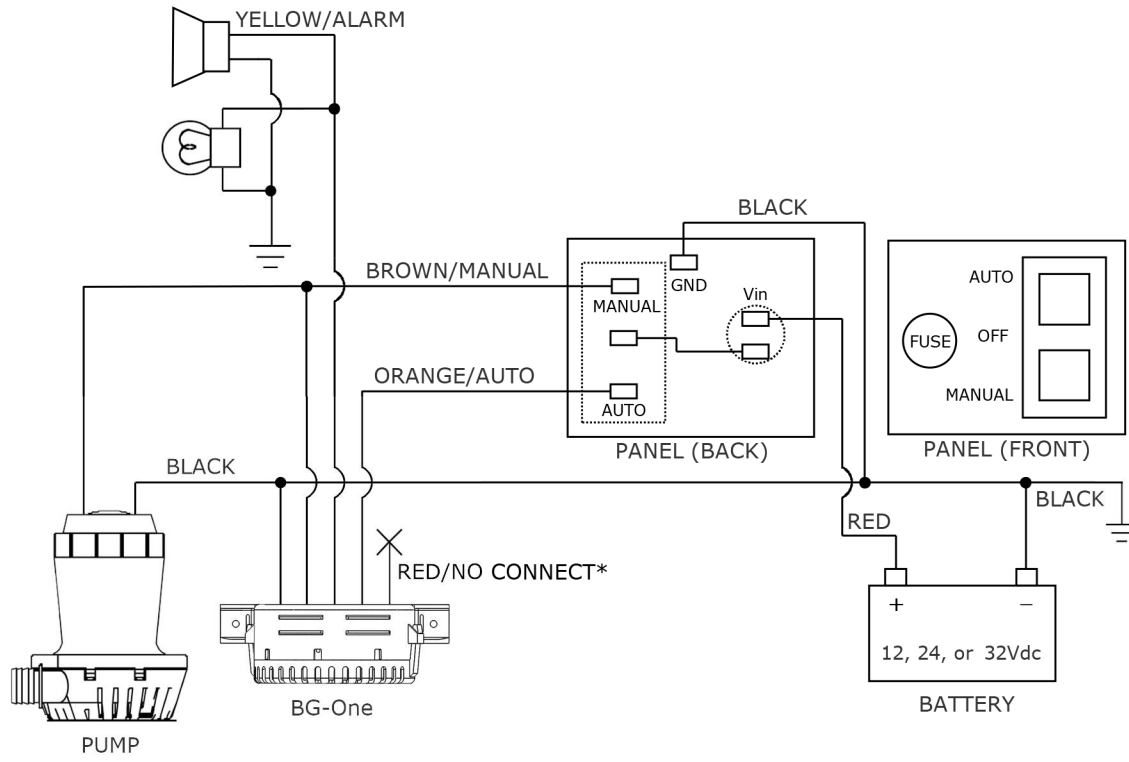

* Don't cut the red wire. Keep it dry and waterproof the end.

Installation: BGI Config App

- The BGI Config App is available on iOS (Apple App Store) or Android (Google Play Store) devices.
- After the BGI Config App is installed open the app and make sure that Bluetooth is enabled on your device.
- Power on the BG-One: You have one minute to access the configuration options before it locks the configuration. To unlock the configuration power cycle the BG-One.
- The factory default values are:
 - Mode of Operation: Mode A (Marina)
 - Pump Run Time: 15 Seconds
 - After Oil Run Time: 3 Seconds
 - Splash Protection: Low
 - Oil Detection Sensitivity: Medium

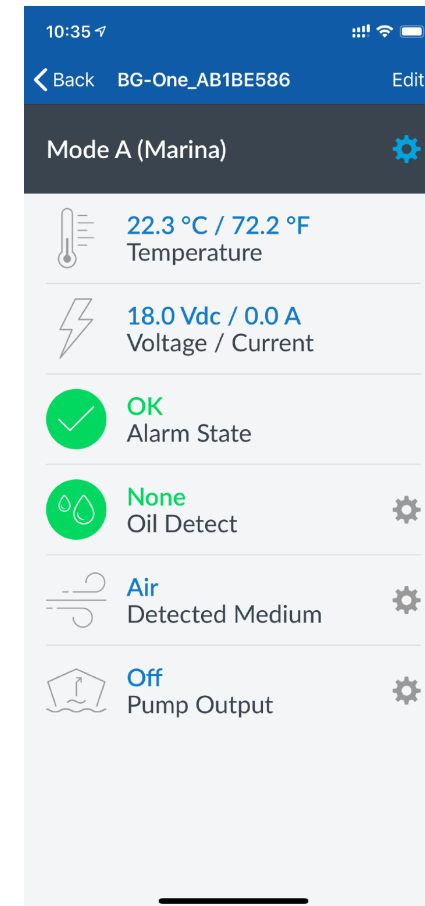

- ← Set Custom Name
- ← Modes of Operation
 - Mode A (Marina)
 - Mode A (Marina: Latching)
 - Mode B (Marina: Sanctuary)
 - Standard Mode (High Seas)
- System Test
 - Activates pump and alarm for three seconds
- Help
- ← Set Oil Detection Sensitivity (How long oil is continuously detected before the alarm activates).
 - Low
 - Medium
 - High
- ← Set Splash Protection (How long water is continuously detected before the pump activates).
 - Off
 - Low
 - Medium
 - High
- ← Set Pump Run Time (When water is detected, the pump will switch ON. Once air is detected, the timer will start. When the timer expires the pump will switch OFF).
 - Configuration Pump Run Time After Water
 - 15-60 Seconds
 - Configuration Pump Run Time After Oil
 - 3-15 Seconds